

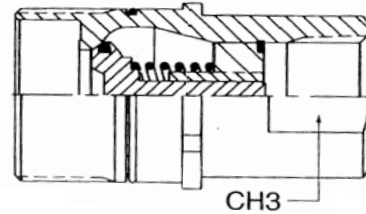

WING NUT HYDRAULIC QUICK COUPLING

PART NUMBER DUST COVER
SF-6
SF-8
SF-10
SF-12

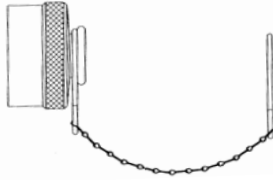

BRASS PLUG

PART NUMBER MALE PLUG	THREAD SIZE FEMALE	WORKING PRESSURE (PSI)	RATED FLOW (GPM)	PARKER INTERCHANGE	AEROQUIP INTERCHANGE
S511-4	1/2" NPT	3000	7	6105-08	5100S2-10B
S511-6	3/4" NPT	3000	18	6105-12	5100S2-12B
S511-8	1" NPT	3000	40	6105-16	5100S2-16B
S511-10	1-1/4" NPT	2750	75	6105-20	5100S2-20B
S511-12	1-1/2" NPT	2500	100	6105-24	5100S2-24B

PART NUMBER FEMALE DUST PLUG
SM-6
SM-8
SM-10
SM-12

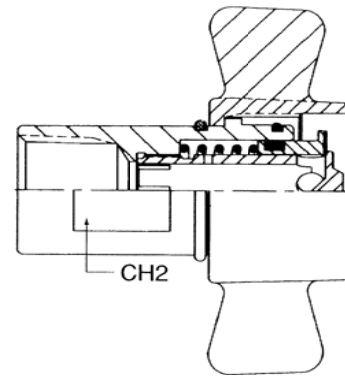
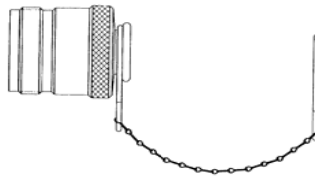

BRASS COUPLER

PART NUMBER FEMALE BODY	THREAD SIZE FEMALE	WORKING PRESSURE (PSI)	RATED FLOW (GPM)	PARKER INTERCHANGE	AEROQUIP INTERCHANGE
S515W-4	1/2" NPT	3000	7	6125-08	5100S5-10B
S515W-6	3/4" NPT	3000	18	6125-12	5100S5-12B
S515W-8	1" NPT	3000	40	6125-16	5100S5-16B
S515W-10	1-1/4" NPT	2750	75	6125-20	5100S5-20B
S515W-12	1-1/2" NPT	2500	100	6125-24	5100S5-24B